



Features and Benefits

- Blend the thickest ingredients to a perfect consistency every time with a 3.5 HP* high performance motor
- 45,000 RPM bare motor speed makes drinks in record time and keeps your customers from waiting
- Easy-to-clean electronic membrane keypad with simple ON/Off, High, Low, Stop and Pulse controls
- Your customers can watch it blend through the clear-view 48 oz. unbreakable container
- Pulse function allows you to add additional ingredients or restore settled drinks
- Limited Three Year Motor and Two Year Parts and Labor Warranty



*Peak input HP



Heavy-Duty 3.5 HP* • *MX1050XTP*



Xtreme Hi-Power Blender Series MX1050XTP



Specifications

Item	Electrical	Listings	RPM (bare motor)	Dimensions (H" x W" x D")	Warranty
MX1050XTP	120 Volt, 13 Amp 50/60 Hz	ETL,NSF	45,000	16"x8½"x8¼"	Limited 3 Year Motor and 2 Year Parts and Labor

Ordering Information

Description	Catalog #	Std Pkg.	Ship Wt. (Lbs.)	Cubic Feet	UPC Code
Xtreme Hi-Power Blender with 48 oz. Polycarbonate Container	MX1050XTP	1	15 lbs.	0.92	040072006715
48 oz. Polycarbonate Container	CAC93	1	3.5 lbs.	0.33	040072004575
Sound Enclosure for Xtreme Series 48 oz. Containers	SE500	1	5 lbs.	0.95	040072007668

MX1050XTP

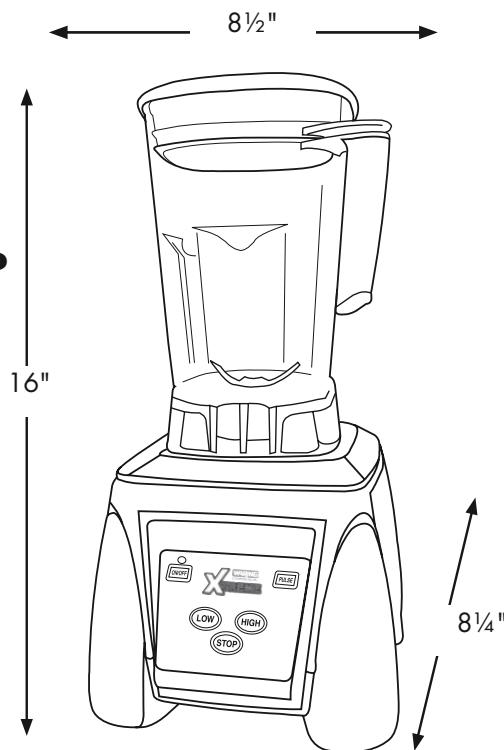

To order Cappuccine products or Waring Commercial Xtreme Blenders:
1-800-511-3127